

FRAMESI
COLOR[®]
LOVER

Repackage Concepts
by Daniel Fox

Industry trends



Current trends in health and beauty package design: Clean, minimalist packaging with simple typography and a focus on essential information is popular. This approach often conveyed a sense of purity and authenticity.

Innovative Shapes and Structures: Unique packaging shapes and structures that stood out on the shelves are gaining popularity. Unconventional designs helped products capture consumers' attention.



Eco-Friendly Colors and Imagery: Earthy tones, natural colors, and botanical imagery were used to emphasize the natural and sustainable aspects of products.





The first batch of designs were very retail store looking. They did not have a boutique feel.

Product line challenges and considerations

The amount of text that needs to be included on the packaging.
The size of the line and how distinguishable the bottle formulas need to be.
There also needs to be some difference between the shampoo and conditioner within each individual formula.

Design Challenges and personal note

This project presented a unique set of design challenges.
How to create eye catching 3D representations of a conceptual product in a 2D medium? What software do I use? How do I make these concepts pleasant to look at?
How do I create as many concepts as possible?

Some of the designs in the following pages are more complete than others. If there are any aspects of any individual concept you would like to combine with another I'm happy to modify and expand on any concept.

This project has really helped me advance as a designer. Over the year I have taught myself 3D modeling in two different applications with a very difficult learning curve. I look forward to learning as much as possible about this process from concept to completion.



Matte Textured Muted color. Sustainable packaging.



Based off Selena Gomez Rare Beauty

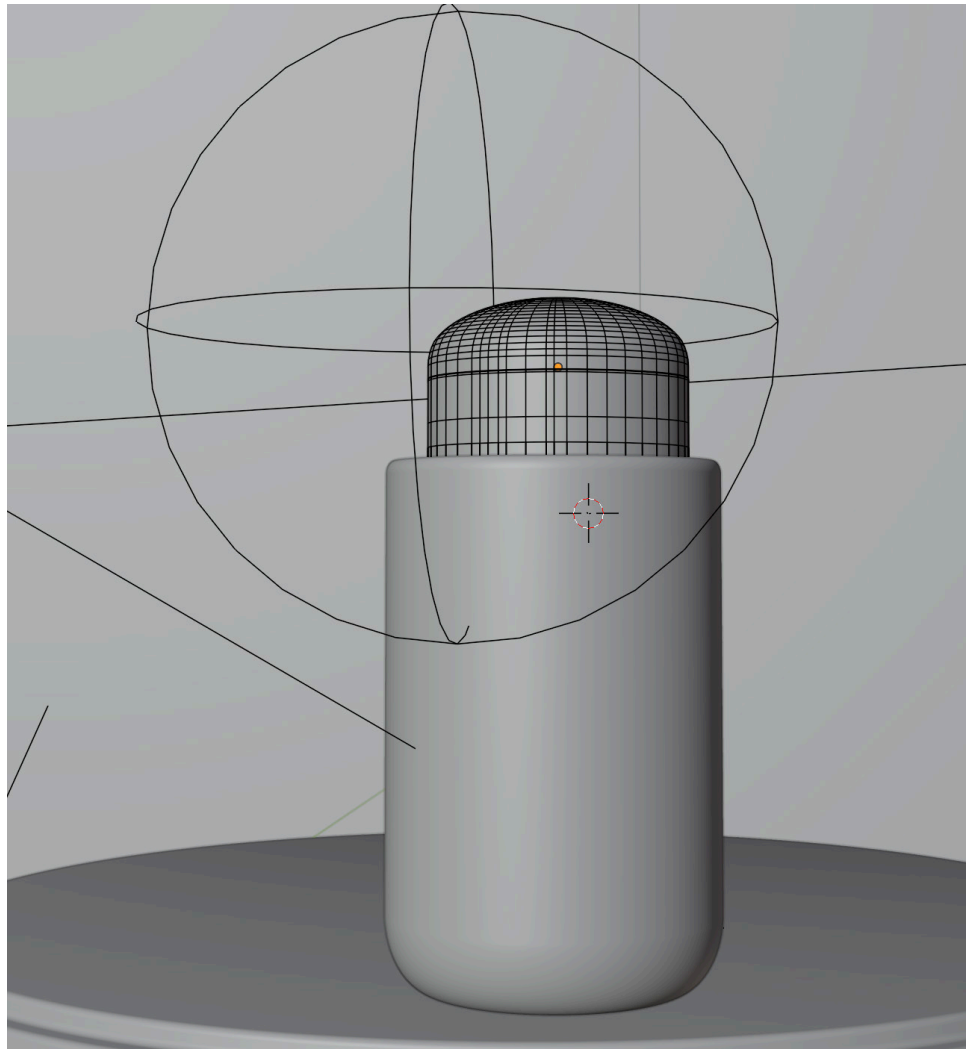



In this example the Diamond strong logo on the Morphosis Mold



In this example the Dynamic Blonde logo on the Morphosis Mold



Bottle is satin matte finished with a smooth feel. The color of the bottle corresponds with the formulation. A white lid differentiates shampoo from conditioner

Bottle is satin matte finished with a smooth feel. The color of the bottle corresponds with the formulation. A white lid differentiates shampoo from conditioner



**Alternate concept where the bottle is white.
The Top of the lid differentiates the conditioner for the shampoo.**





**Bottle is matte finished. Bottle is very soft plastic.
The Shampoo bottle is slightly opaque**





**Bottle is matte finished and very soft plastic.
Only the ring around the lid and the logo's itself would change color.**

Lid pops up revealing a hole for the shampoo to come out





TOP OF CAP FEATURES A
EMBOSSSED F FROM THE
FRAMESI LOGO



LOGO TREATMENTS
ARE VERY SIMILAR TO
THE STYLING PROD-
UCTS. THREE VARIA-
TIONS BELOW

DIAMOND
STRONG
SHAMPOO

STRENGTHEN, REPAIR
& RESTORE
SHAMPOING FORTIFIANT,
RÉPARATEUR ET RESTRUCTURANT
CHAMPÚ FORTALECEDOR,
REPARADOR Y RESTAURADOR

DIAMOND
STRONG
SHAMPOO

STRENGTHEN, REPAIR & RESTORE
SHAMPOING FORTIFIANT,
RÉPARATEUR ET RESTRUCTURANT
CHAMPÚ FORTALECEDOR,
REPARADOR Y RESTAURADOR

DIAMOND
STRONG
SHAMPOO

STRENGTHEN, REPAIR & RESTORE
SHAMPOING FORTIFIANT,
RÉPARATEUR ET RESTRUCTURANT
CHAMPÚ FORTALECEDOR,
REPARADOR Y RESTAURADOR

Bottle is matte finished with a textured feel. The
color of the bottle corresponds with the
Shampoo formulation. (See Below)

DYNAMIC
BLONDE



MOISTURE
RICH



VOLUME
BOOST



SMOOTH
SHINE



CURL
DEFINE













FRAMESI
**COLOR
LOVER**



DIAMOND
STRONG
SHAMPOO

STRENGTHEN, REPAIR
& RESTORE

SHAMPOING FORTIFIANT,
RÉPARATEUR ET RESTRUCTURANT
CHAMPÚ FORTALECEDOR,
REPARADOR Y RESTAURADOR

VEGAN
FREE FROM SULFATES, PARABENS,
GLUTEN, DEA & SODIUM CHLORIDE

1000 mL / 33.8 fl. oz.

FRAMESI
**COLOR
LOVER**



DIAMOND
STRONG
SHAMPOO

STRENGTHEN, REPAIR
& RESTORE

SHAMPOING FORTIFIANT,
RÉPARATEUR ET RESTRUCTURANT
CHAMPÚ FORTALECEDOR,
REPARADOR Y RESTAURADOR

VEGAN
FREE FROM SULFATES, PARABENS,
GLUTEN, DEA & SODIUM CHLORIDE

500 mL / 16.9 fl. oz.

FRAMESI
**COLOR
LOVER**



DIAMOND
STRONG
SHAMPOO

STRENGTHEN, REPAIR
& RESTORE

SHAMPOING FORTIFIANT,
RÉPARATEUR ET RESTRUCTURANT
CHAMPÚ FORTALECEDOR,
REPARADOR Y RESTAURADOR

VEGAN
FREE FROM SULFATES, PARABENS,
GLUTEN, DEA & SODIUM CHLORIDE

250 mL / 8.45 fl. oz.







FRAMESI
**COLOR
LOVER**



MOISTURE
RICH
SHAMPOO

Shampooing Riche et Hydratant
Champu Hidratante

500mL / 16.9fl. oz.

Vegan, Sulfate Free, Paraben Free,
Gluten Free, LCA Free, Sodium Chloride Free

FRAMESI
**COLOR
LOVER**



DYNAMIC
BLONDE
SHAMPOO

Shampooing Violet Pour Cheveux Blonds Ou Gris
Champu Violeta Para Cabellos Rubios/Grises

500mL / 16.9fl. oz.

Vegan, Sulfate Free, Paraben Free, Gluten Free,
DEA Free, Sodium Chloride Free





FRAMESI
**COLOR[®]
LOVER**



**DIAMOND
STONG
SHAMPOO**

STRENGTHEN, REPAIR & RESTORE
SHAMPOING FORTIFIANT,
RÉPARATEUR ET RESTRUCTURANT
CHAMPU FORTALECEDOR,
REPARADOR Y RESTAURADOR

500 mL / 16.9 fl. oz.
VEGAN
SULFATE FREE, PARABEN FREE, GLUTEN FREE,
DEA FREE, SODIUM CHLORIDE FREE

FRAMESI
**COLOR[®]
LOVER**

**DIAMOND
STONG
SHAMPOO**

STRENGTHEN, REPAIR & RESTORE
SHAMPOING FORTIFIANT,
RÉPARATEUR ET RESTRUCTURANT
CHAMPU FORTALECEDOR,
REPARADOR Y RESTAURADOR

1000 mL / 33.8 fl. oz.
VEGAN
SULFATE FREE, PARABEN FREE, GLUTEN FREE,
DEA FREE, SODIUM CHLORIDE FREE

FRAMESI
**COLOR[®]
LOVER**



**DIAMOND
STONG
SHAMPOO**

STRENGTHEN, REPAIR & RESTORE
SHAMPOING FORTIFIANT,
RÉPARATEUR ET RESTRUCTURANT
CHAMPU FORTALECEDOR,
REPARADOR Y RESTAURADOR

500 mL / 16.9 fl. oz.
VEGAN
SULFATE FREE, PARABEN FREE, GLUTEN FREE,
DEA FREE, SODIUM CHLORIDE FREE





FRAMESI
COLOR LOVER

DIAMOND
STRONG
CONDITIONER

STRENGTHEN, REPAIR & RESTORE
RENFORCER, RÉPARER ET RESTAURER
REPARATEUR ET RESTRUCTURANT
ACONDICIONADOR FORTALECEDOR,
REPARADOR Y RESTAURADOR

VEGAN
FREE FROM SULFATES, PARABENS,
GLUTEN, DEA & SODIUM CHLORIDE
500 mL / 16.9 fl. oz.

FRAMESI
COLOR LOVER

DIAMOND
STRONG
CONDITIONER

STRENGTHEN, REPAIR & RESTORE
RENFORCER, RÉPARER ET RESTAURER
REPARATEUR ET RESTRUCTURANT
ACONDICIONADOR FORTALECEDOR,
REPARADOR Y RESTAURADOR

VEGAN
FREE FROM SULFATES, PARABENS,
GLUTEN, DEA & SODIUM CHLORIDE
1000 mL / 33.8 fl. oz.

FRAMESI
COLOR LOVER

DIAMOND
STRONG
SHAMPOO

STRENGTHEN, REPAIR & RESTORE
RENFORCER, RÉPARER ET RESTAURER
REPARATEUR ET RESTRUCTURANT
CHAMPO FORTALECEDOR,
DEPARADOR Y RESTAURADOR

VEGAN
FREE FROM SULFATES, PARABENS,
GLUTEN, DEA & SODIUM CHLORIDE
1000 mL / 33.8 fl. oz.

FRAMESI
COLOR LOVER

DIAMOND
STRONG
SHAMPOO

STRENGTHEN, REPAIR & RESTORE
RENFORCER, RÉPARER ET RESTAURER
REPARATEUR ET RESTRUCTURANT
CHAMPO FORTALECEDOR,
REPARADOR Y RESTAURADOR

VEGAN
FREE FROM SULFATES, PARABENS,
GLUTEN, DEA & SODIUM CHLORIDE
500 mL / 16.9 fl. oz.







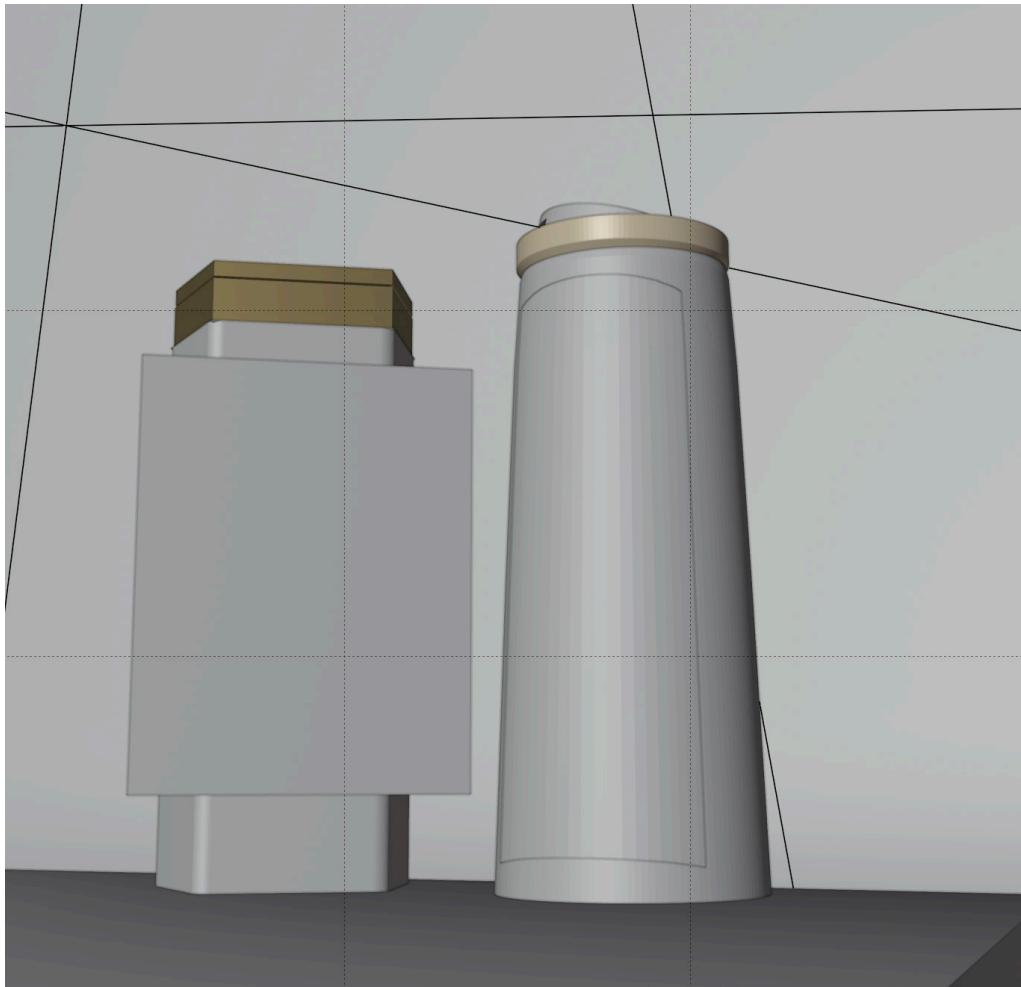











FRAMESI
**COLOR
LOVER**

**DYNAMIC BLONDE
CONDITIONER**

Vegan, Sulfate Free,
Paraben Free, Gluten Free,
DEA Free, Sodium Chloride Free

500mL / 16.9fl. oz.

FRAMESI
**COLOR
LOVER**



**VOLUME
BOOST
SHAMPOO**

Shampooing Violet Pour Cheveux Blonds Ou Gris
Champu Violeta Para Cabelos Rubios/Grises

Vegan, Sulfate Free, Paraben Free,
Gluten Free, DEA Free,
Sodium Chloride Free

500mL / 16.9fl. oz.

FRAMESI
**COLOR
LOVER**



**MOISTURE RICH
SHAMPOO**

Shampooing Riche et Hydratant
Champu Hidratante

framesi
MILAN
500mL / 16.9fl. oz.

Vegan, Sulfate Free, Paraben Free,
Gluten Free, DEA Free, Sodium Chloride Free

